

PLATTEGROND GEWIJZIGDE SITUATIE

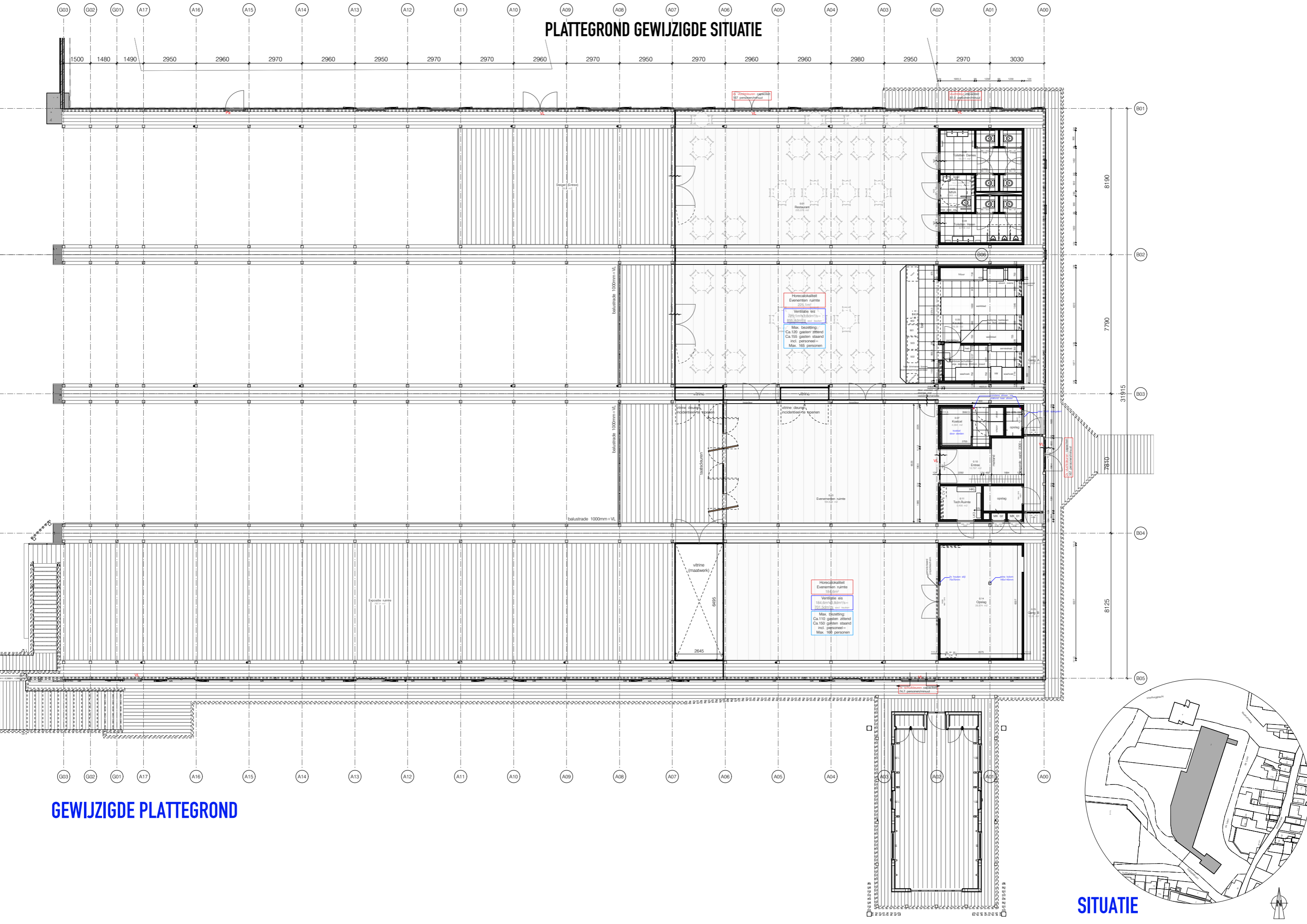

GEWIJZIGDE PLATTEGROND

SITUATIE



GEVELS EN DOORSNEDEN

-BESTAAND-

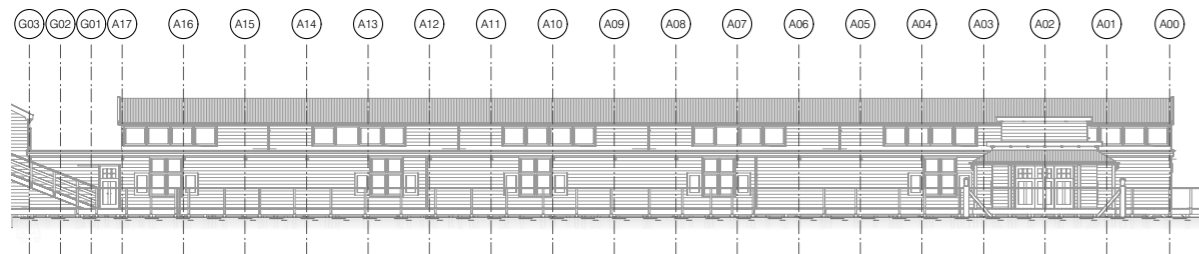

OOST GEVEL, SCHIP I

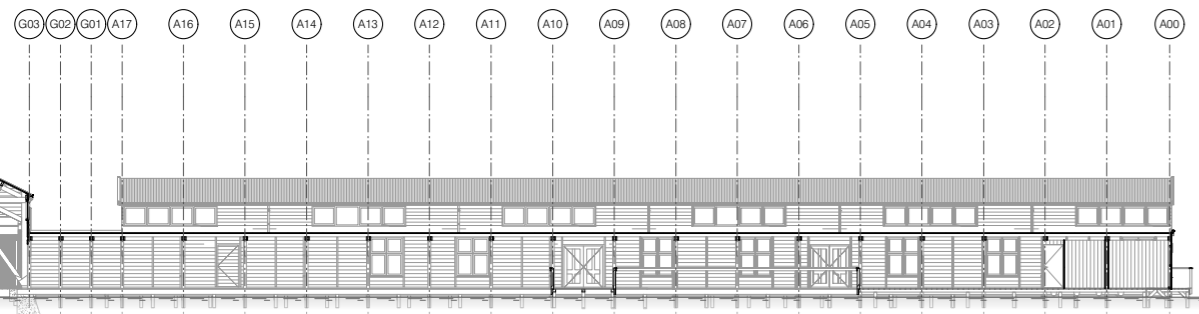

LANGSDOORSNEDE, SCHIP I



NOORD GEVEL, SCHIP I

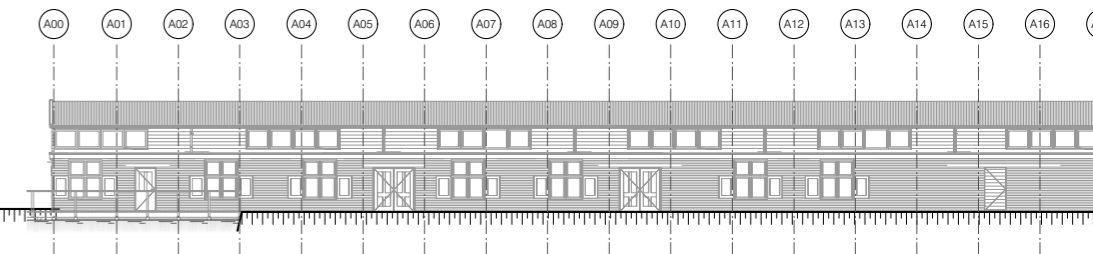

WEST GEVEL, SCHIP I

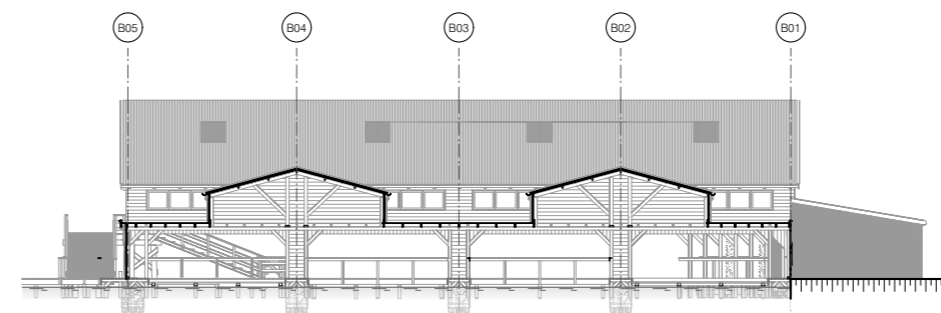

DWARSDOORSNEDE, SCHIP I

-GEWIJZIGD-

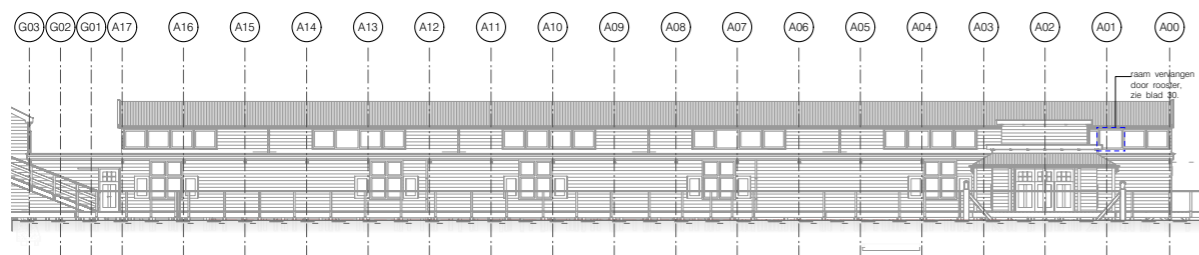

OOST GEVEL, SCHIP I

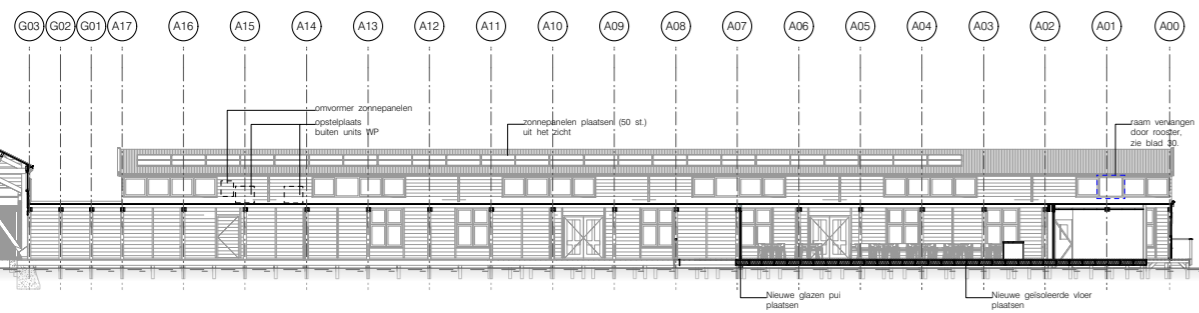

LANGSDOORSNEDE, SCHIP I

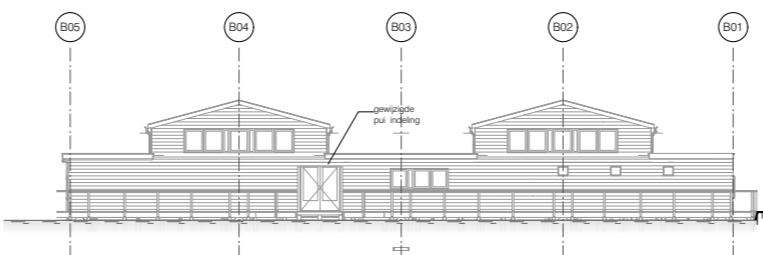

NOORD GEVEL, SCHIP I

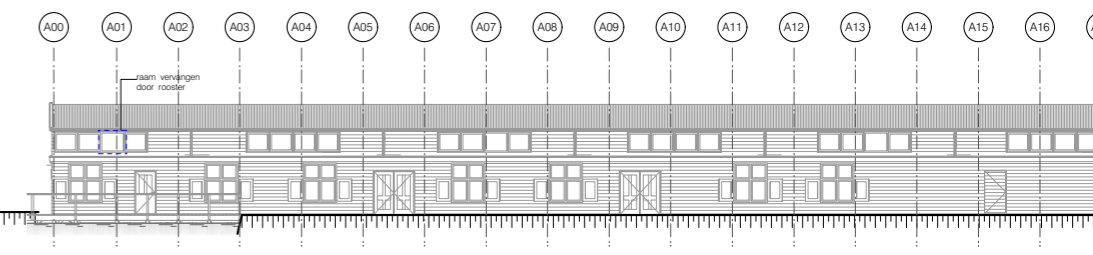

WEST GEVEL, SCHIP I

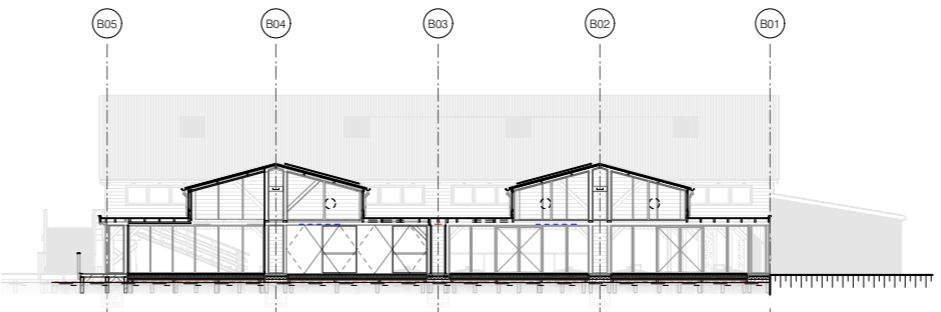

DWARSDOORSNEDE, SCHIP I

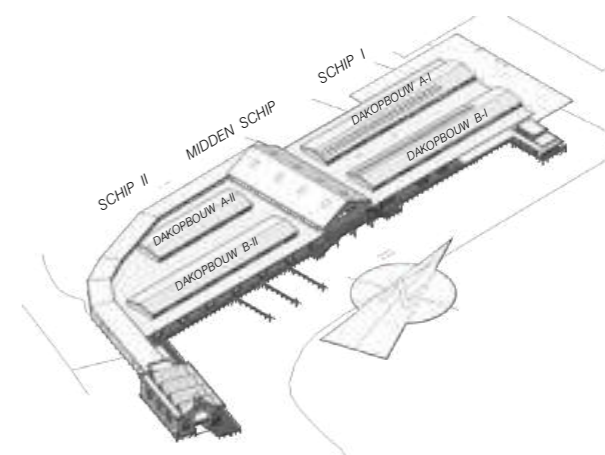

ISOMETRIE

DETAIL DOORSNEDEN

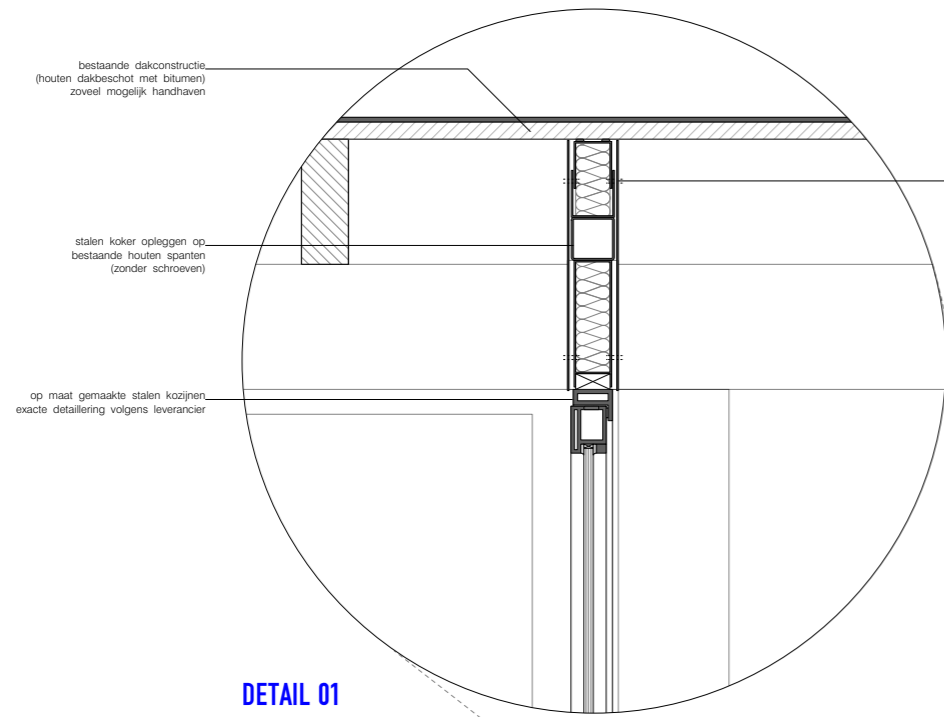

DETAIL 01

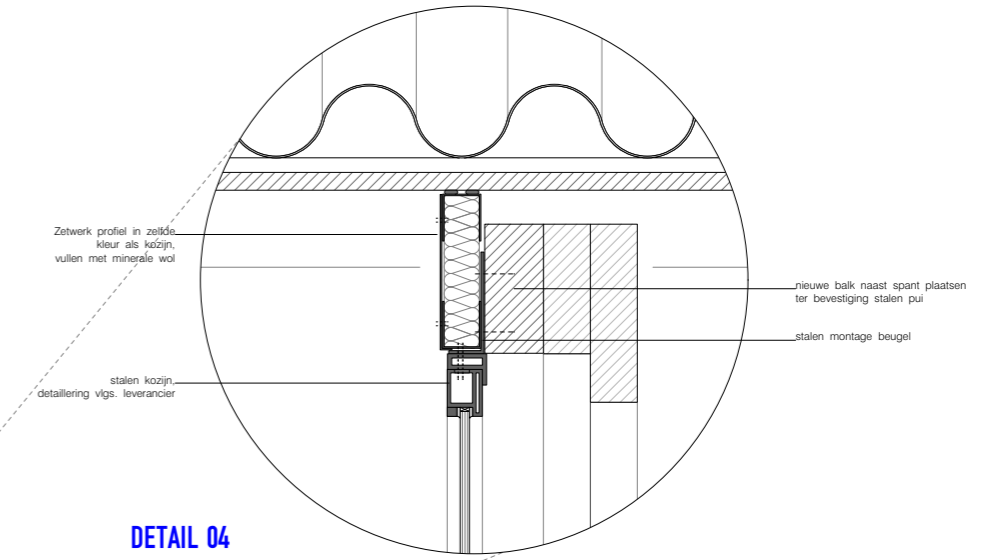

DETAIL 04

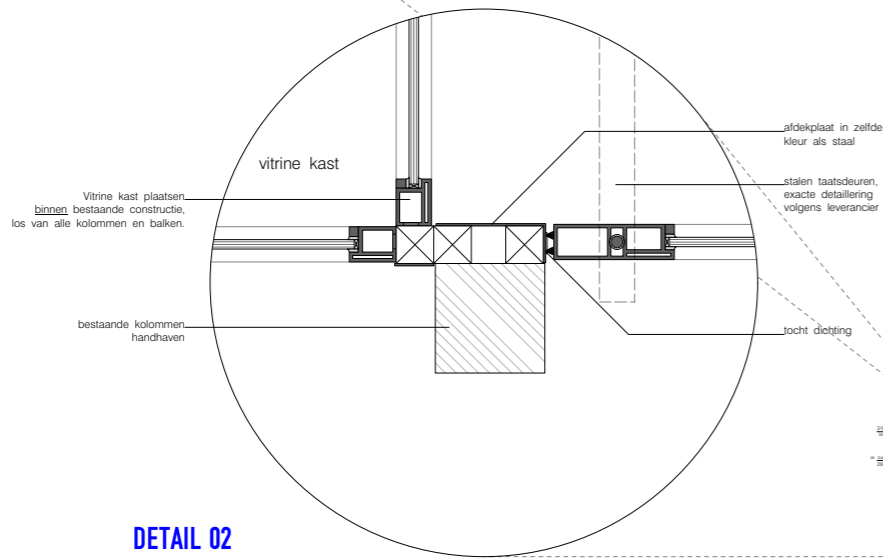

DETAIL 02

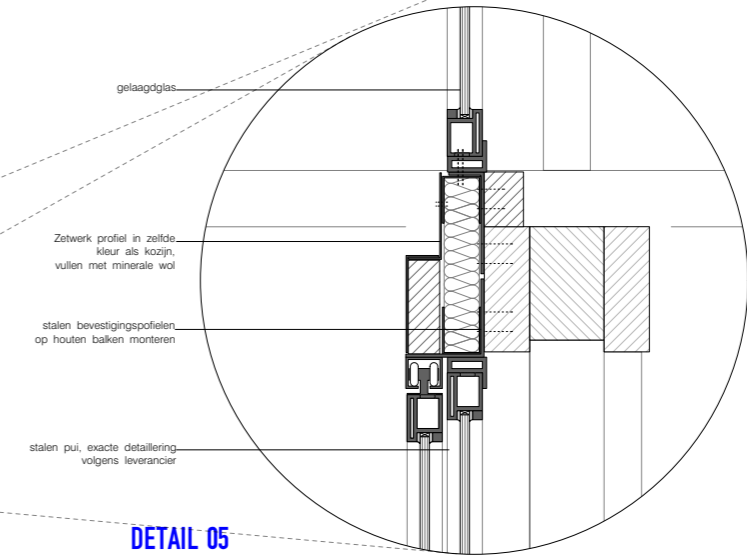

DETAIL 05

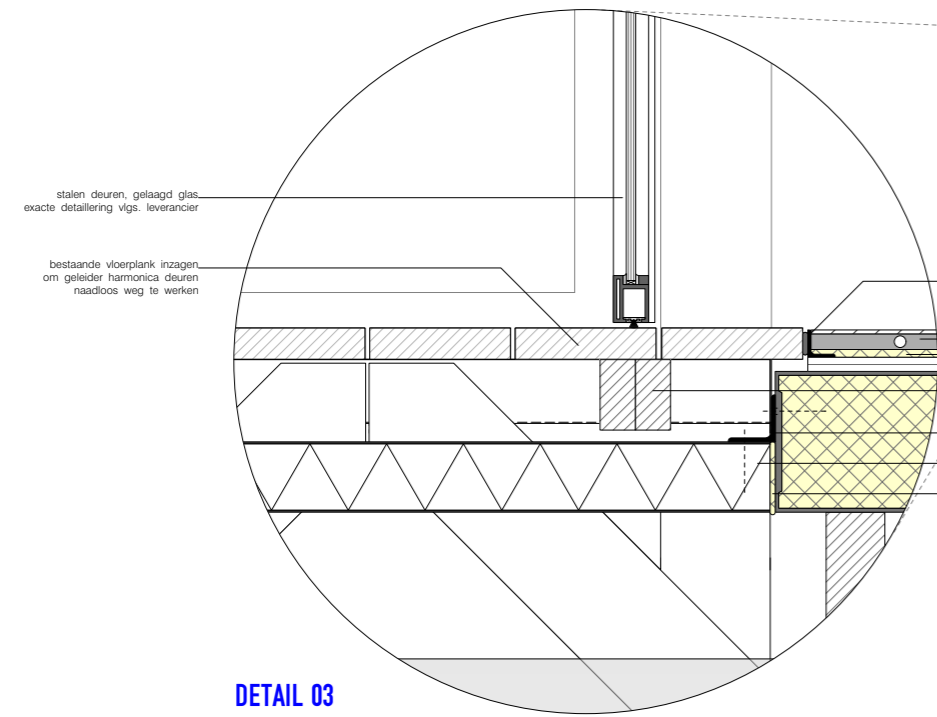
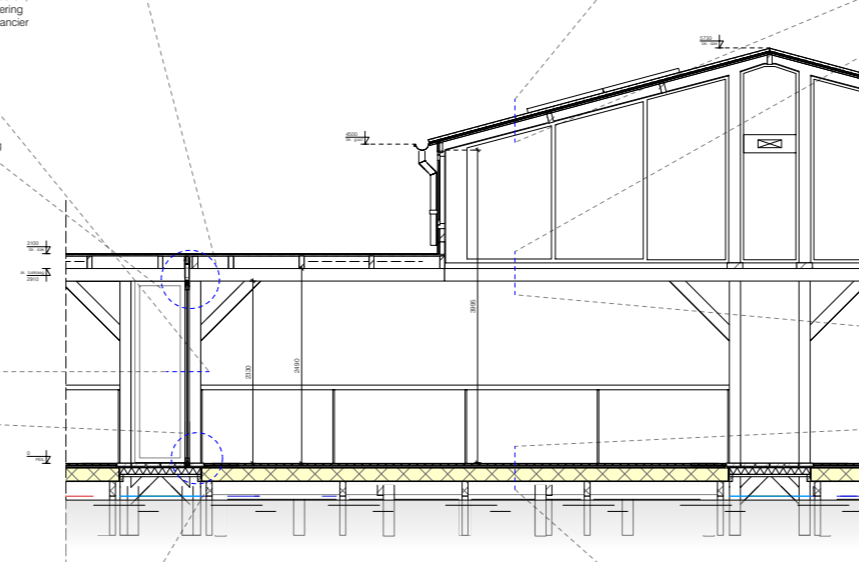

DETAIL 03

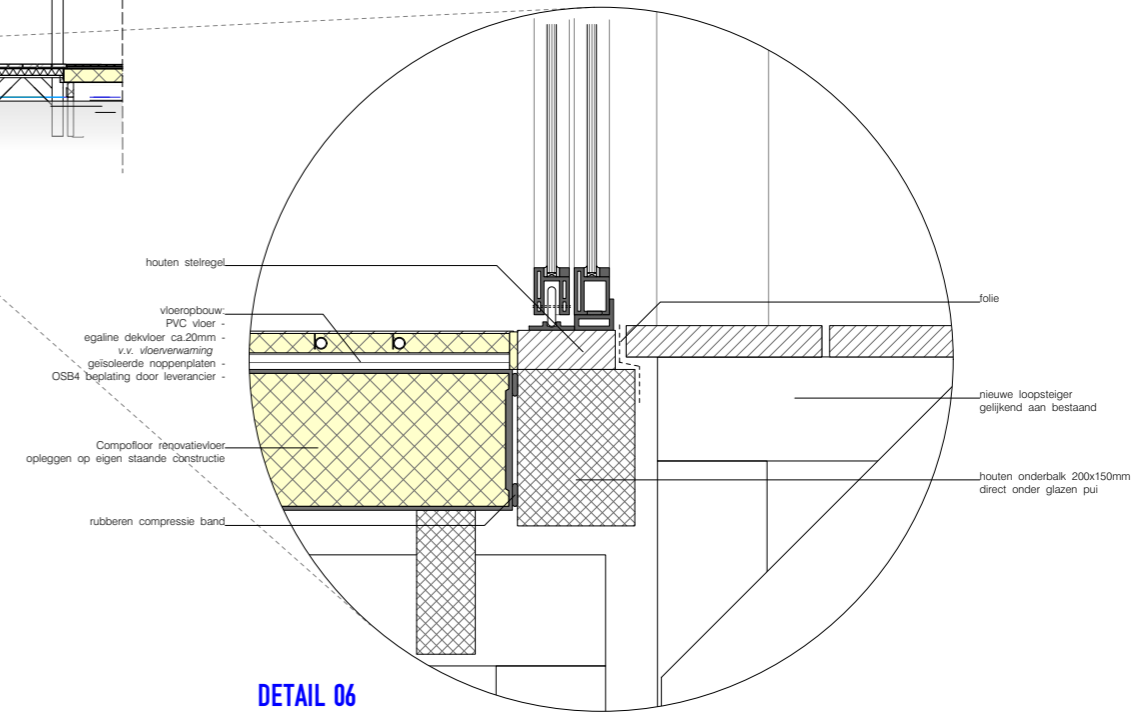

DETAIL 06

ISOMETRIE

